

Condensing unit
Voltage Code : TZ

TAJN2464ZBR-TZ

Low Temp. Commercial (BP)

400V 3~ 50Hz / 440V 3~ 60 Hz

R452A / R404A / R448A / R449A

TAJN2464ZBR-TZ

Conditions	Frequency	Nominal Cooling Capacity		Sound Power ISO3745 / ISO 3743-1
		Watts	BTU/h	
Standard TE / R452A	50 Hz / 60 Hz	1397 / 1380	4762 / 4706	65 dBA
Standard TE / R404A	50 Hz / 60 Hz	1501 / 1484	5120 / 5060	65 dBA
Standard TE / R448A	50 Hz / 60 Hz	1248 / 1247	4255 / 4251	65 dBA
Standard TE / R449A	50 Hz / 60 Hz	1250 / 1249	4261 / 4257	65 dBA

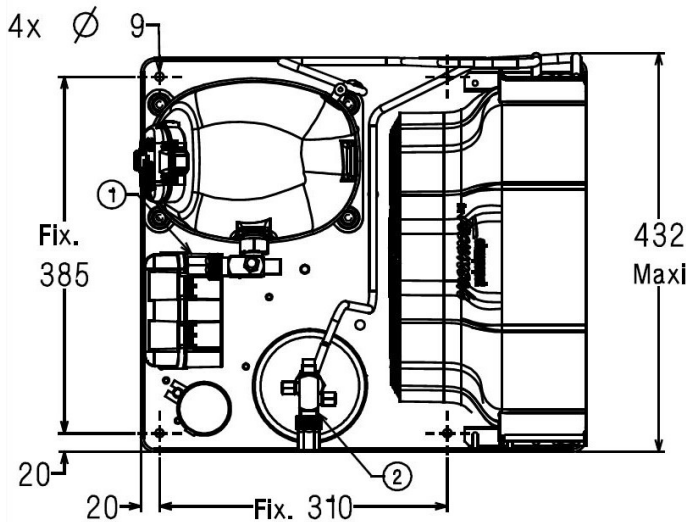
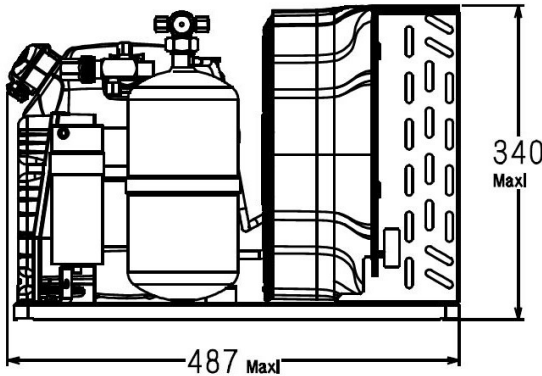

* Standard TE : T°Ambient 32.0°C / T°Evap. -23.3°C / T°Return gas temp.. 32.0°C
T°Subcooling. 2.0K

Net Weight (Kg)	34.0
Expansion device	Expansion_Valve
Air Flow (m³/h)	900 / 900
Compo Data Sheet	124SU-TZ
Elec Comp Type	TRI
Current (Amp)	
Load Rated Amp	2.4 2.3
Max Cont Current	4 4.2
Lock Rotor Amp	16.1 16.5
Fan	
Speed (rpm)	1200 / 1200
Power (W)	30.0
Diameter (mm)	300
Protection	Overload
IP Level	IP54
Condenser	M300/3900
Liquid Receiver	
Capacity (L)	2.35
Maximum Pressure (Bars)	32.0
Suction Line	
Suction Type	Vanne Orientable
For Tubing Out Diam	15.9 (5/8")
Suction Connection Type	Brased
Liquid Line	
Liquid Line Type	Vanne Orientable
For Tubing Out Diam	9.5 (3/8")
Liquid Connecton Type	Brased
Connection Type	VR
Fan Guard	maille < à 8mm

Note : Tecumseh reserves the right to change information contained in this document without notification.



Tecumseh

TAJN2464ZBR-TZ	Tension TZ : 400V 3~ 50Hz / 440V 3~ 60 Hz
-----------------------	--

Les performances sont données dans les conditions Standard TE :	Gaz aspirés :	32.0 °C
Condition Dew	Sous refroidissement :	2.0 K
The performance data are in Standard TE conditions :	Return gas :	32.0 °C
Dew Condition	Subcooling :	2.0 K

© 2021 Tecumseh Products Company
All rights reserved

50 Hz R452A

N°6024

5 T ambience	6 T évaporation	(°C)	-40	-35	-30	-25	-20	-15	-10
25	1 P frigorifique	(Watt)	684	912	1173	1464	1782	2123	2484
	2 P absorbée	(W)	633	750	880	1024	1188	1374	1586
	3 I absorbée	(A)	1.70	1.82	1.98	2.17	2.41	2.67	2.98
	4 Tc	(°C)	28.9	31.1	33.6	36.4	39.4	42.7	46.2
32	1 P frigorifique	(Watt)	582	794	1034	1300	1590	1901	2229
	2 P absorbée	(W)	618	747	887	1042	1215	1411	1632
	3 I absorbée	(A)	1.67	1.82	1.99	2.20	2.45	2.72	3.04
	4 Tc	(°C)	35.1	37.1	39.4	42.0	44.9	48.0	51.4
43	1 P frigorifique	(Watt)		608	816	1044	1292	1558	1845
	2 P absorbée	(W)		724	884	1057	1248	1460	1697
	3 I absorbée	(A)		1.79	2.00	2.23	2.49	2.79	3.11
	4 Tc	(°C)		46.7	48.6	50.9	53.5	56.4	59.5

60 Hz R452A

N°6024

5 T ambience	6 T évaporation	(°C)	-40	-35	-30	-25	-20	-15	-10
25	1 P frigorifique	(Watt)	663	899	1168	1468	1796	2151	2528
	2 P absorbée	(W)	710	863	1024	1201	1402	1635	1909
	3 I absorbée	(A)	1.58	1.75	1.95	2.19	2.47	2.79	3.14
	4 Tc	(°C)	33.9	35.9	38.3	41.0	43.9	47.1	50.5
32	1 P frigorifique	(Watt)	548	765	1010	1282	1579	1898	2242
	2 P absorbée	(W)	674	842	1017	1208	1423	1670	1958
	3 I absorbée	(A)	1.54	1.73	1.95	2.21	2.50	2.83	3.19
	4 Tc	(°C)	40.5	42.3	44.5	47.0	49.7	52.8	56.0
43	1 P frigorifique	(Watt)		565	772	999	1249		
	2 P absorbée	(W)		792	994	1211	1451		
	3 I absorbée	(A)		1.68	1.94	2.22	2.53		
	4 Tc	(°C)		52.5	54.3	56.5	59.0		

1 = cooling capacity 2 = power input 3 = current 4 = condensing temperature 5 = ambient temperature 6 = evaporating temperature

Nota : Tecumseh se réserve le droit de modifier les informations contenues dans ce document sans préavis.

Note : Tecumseh reserves the right to change information contained in this document without notification.



Tecumseh

TAJN2464ZBR-TZ	Tension TZ : 400V 3~ 50Hz / 440V 3~ 60 Hz
-----------------------	--

Les performances sont données dans les **conditions Standard TE** :
 Condition Dew
 The performance data are in **Standard TE conditions** :
 Dew Condition

Gaz aspirés : 32.0 °C
 Sous refroidissement : 2.0 K
 Return gas : 32.0 °C
 Subcooling : 2.0 K

© 2021 Tecumseh Products Company
All rights reserved

50 Hz R404A

N°5054

5 T ambience	6 T évaporation	(°C)	-40	-35	-30	-25	-20	-15	-10
25	1 P frigorifique	(Watt)	770	1010	1283	1583	1904	2240	2582
	2 P absorbée	(W)	679	806	943	1094	1262	1452	1667
	3 I absorbée	(A)	1.81	1.95	2.11	2.31	2.55	2.82	3.13
	4 Tc	(°C)	31.4	33.8	36.3	39.1	42.1	45.3	48.8
32	1 P frigorifique	(Watt)	662	884	1133	1405	1694	1995	2300
	2 P absorbée	(W)	671	808	955	1116	1294	1494	1720
	3 I absorbée	(A)	1.80	1.95	2.13	2.35	2.59	2.88	3.20
	4 Tc	(°C)	37.5	39.7	42.1	44.7	47.6	50.7	54.0
43	1 P frigorifique	(Watt)	493	686	898	1126	1366	1614	1865
	2 P absorbée	(W)	640	794	959	1138	1335	1554	1798
	3 I absorbée	(A)	1.77	1.95	2.15	2.39	2.65	2.96	3.29
	4 Tc	(°C)	47.1	49.0	51.2	53.6	56.2	59.0	62.1

60 Hz R404A

N°5054

5 T ambience	6 T évaporation	(°C)	-40	-35	-30	-25	-20	-15	-10
25	1 P frigorifique	(Watt)	750	999	1279	1588	1919	2265	2621
	2 P absorbée	(W)	769	933	1103	1287	1493	1732	2011
	3 I absorbée	(A)	1.70	1.87	2.09	2.33	2.62	2.94	3.30
	4 Tc	(°C)	36.3	38.5	40.9	43.6	46.4	49.5	52.9
32	1 P frigorifique	(Watt)	629	856	1109	1386	1680	1987	2302
	2 P absorbée	(W)	743	918	1101	1298	1520	1773	2069
	3 I absorbée	(A)	1.67	1.87	2.10	2.36	2.66	2.99	3.37
	4 Tc	(°C)	42.7	44.7	47.0	49.5	52.2	55.2	58.3
43	1 P frigorifique	(Watt)		638	848	1074	1313		
	2 P absorbée	(W)		878	1086	1310	1558		
	3 I absorbée	(A)		1.84	2.10	2.38	2.70		
	4 Tc	(°C)		54.5	56.5	58.8	61.3		

1 = cooling capacity 2 = power input 3 = current 4 = condensing temperature 5 = ambient temperature 6 = evaporating temperature

Nota : Tecumseh se réserve le droit de modifier les informations contenues dans ce document sans préavis.

Note : Tecumseh reserves the right to change information contained in this document without notification.



Tecumseh

TAJN2464ZBR-TZ	Tension TZ : 400V 3~ 50Hz / 440V 3~ 60 Hz
-----------------------	--

Les performances sont données dans les conditions Standard TE :	Gaz aspirés :	32.0 °C
Condition Dew	Sous refroidissement :	2.0 K
The performance data are in Standard TE conditions :	Return gas :	32.0 °C
Dew Condition	Subcooling :	2.0 K

50 Hz R448A (*)							
							N°6927
5 T ambience	6 T évaporation	(°C)	-30	-25	-20	-15	-10
25	1 P frigorifique	(Watt)	990	1288	1622	1990	2386
	2 P absorbée	(W)	840	982	1139	1315	1514
	3 I absorbée	(A)	1.89	2.08	2.30	2.56	2.84
	4 Tc	(°C)	33.6	36.1	38.9	42.0	45.5
32	1 P frigorifique	(Watt)	873	1147	1456	1797	2169
	2 P absorbée	(W)	850	1002	1169	1356	1565
	3 I absorbée	(A)	1.91	2.11	2.35	2.61	2.91
	4 Tc	(°C)	39.6	42.0	44.7	47.6	51.0
43	1 P frigorifique	(Watt)		939	1211	1515	
	2 P absorbée	(W)		1022	1207	1412	
	3 I absorbée	(A)		2.15	2.41	2.69	
	4 Tc	(°C)		51.3	53.7	56.5	

60 Hz R448A (*)							
							N°6927
5 T ambience	6 T évaporation	(°C)	-30	-25	-20	-15	-10
25	1 P frigorifique	(Watt)	985	1295	1646	2035	2460
	2 P absorbée	(W)	978	1152	1346	1568	1827
	3 I absorbée	(A)	1.87	2.10	2.37	2.67	3.01
	4 Tc	(°C)	38.4	40.7	43.4	46.4	49.8
32	1 P frigorifique	(Watt)	857	1141	1464	1826	2224
	2 P absorbée	(W)	975	1163	1372	1608	1883
	3 I absorbée	(A)	1.87	2.13	2.41	2.72	3.07
	4 Tc	(°C)	44.7	47.0	49.5	52.4	55.6
43	1 P frigorifique	(Watt)		924			
	2 P absorbée	(W)		1172			
	3 I absorbée	(A)		2.14			
	4 Tc	(°C)		56.8			

1 = cooling capacity 2 = power input 3 = current 4 = condensing temperature 5 = ambient temperature 6 = evaporating temperature

(*) Veuillez vous référer strictement aux Recommandations d'Utilisation et Bulletins Marketing Tecumseh du fait de la température de reflux élevée pour les applications LBP.
 (*) Due to very high discharge temperature especially on LBP conditions, please strictly refer to Tecumseh Guidelines & Marketing Bulletin when using this refrigerant.

Nota : Tecumseh se réserve le droit de modifier les informations contenues dans ce document sans préavis.
Note : Tecumseh reserves the right to change information contained in this document without notification.

© 2021 Tecumseh Products Company
All rights reserved



Tecumseh

TAJN2464ZBR-TZ	Tension TZ : 400V 3~ 50Hz / 440V 3~ 60 Hz
-----------------------	--

Les performances sont données dans les conditions Standard TE :	Gaz aspirés :	32.0 °C
Condition Dew	Sous refroidissement :	2.0 K
The performance data are in Standard TE conditions :	Return gas :	32.0 °C
Dew Condition	Subcooling :	2.0 K

50 Hz R449A (*)							
							N°5550
5 T ambience	6 T évaporation	(°C)	-30	-25	-20	-15	-10
25	1 P frigorifique	(Watt)	991	1289	1624	1992	2389
	2 P absorbée	(W)	840	982	1139	1315	1514
	3 I absorbée	(A)	1.89	2.08	2.30	2.56	2.84
	4 Tc	(°C)	33.6	36.1	38.9	42.0	45.5
32	1 P frigorifique	(Watt)	874	1148	1457	1800	2172
	2 P absorbée	(W)	850	1002	1169	1356	1565
	3 I absorbée	(A)	1.91	2.11	2.35	2.61	2.91
	4 Tc	(°C)	39.6	42.0	44.6	47.6	50.9
43	1 P frigorifique	(Watt)		940	1213	1517	
	2 P absorbée	(W)		1022	1207	1412	
	3 I absorbée	(A)		2.15	2.41	2.69	
	4 Tc	(°C)		51.2	53.7	56.4	

60 Hz R449A (*)							
							N°5550
5 T ambience	6 T évaporation	(°C)	-30	-25	-20	-15	-10
25	1 P frigorifique	(Watt)	986	1297	1648	2038	2463
	2 P absorbée	(W)	978	1152	1346	1568	1827
	3 I absorbée	(A)	1.87	2.10	2.37	2.67	3.01
	4 Tc	(°C)	38.4	40.7	43.4	46.4	49.8
32	1 P frigorifique	(Watt)	858	1143	1466	1828	2227
	2 P absorbée	(W)	975	1163	1372	1608	1883
	3 I absorbée	(A)	1.87	2.13	2.41	2.72	3.07
	4 Tc	(°C)	44.7	46.9	49.5	52.3	55.5
43	1 P frigorifique	(Watt)		925			
	2 P absorbée	(W)		1172			
	3 I absorbée	(A)		2.14			
	4 Tc	(°C)		56.7			

1 = cooling capacity 2 = power input 3 = current 4 = condensing temperature 5 = ambient temperature 6 = evaporating temperature

(*) Veuillez vous référer strictement aux Recommandations d'Utilisation et Bulletins Marketing Tecumseh du fait de la température de reflux élevée pour les applications LBP.
 (*) Due to very high discharge temperature especially on LBP conditions, please strictly refer to Tecumseh Guidelines & Marketing Bulletin when using this refrigerant.

Nota : Tecumseh se réserve le droit de modifier les informations contenues dans ce document sans préavis.

Note : Tecumseh reserves the right to change information contained in this document without notification.

© 2021 Tecumseh Products Company
All rights reserved