

SPRĘŻARKA CUBIGEL MS34TB-T

ZASTOSOWANIE ŚREDNIO I WYSOKOTEMPERATUROWE HMBP 50Hz
R404A/R507

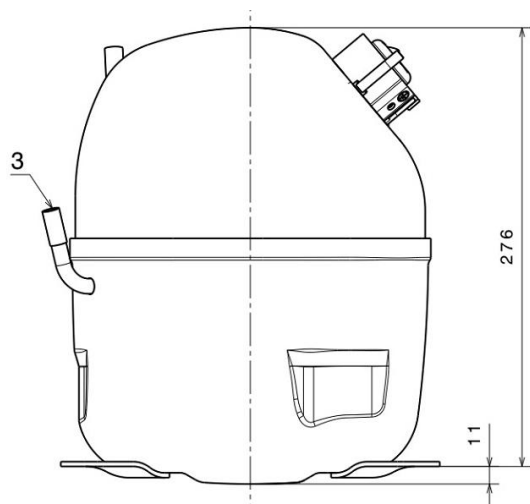

Ø MM

(1) SSANIE	12,7
------------	------

(2) SERWIS	9,70
------------	------

(3) TŁOCZENIE	8,00
---------------	------

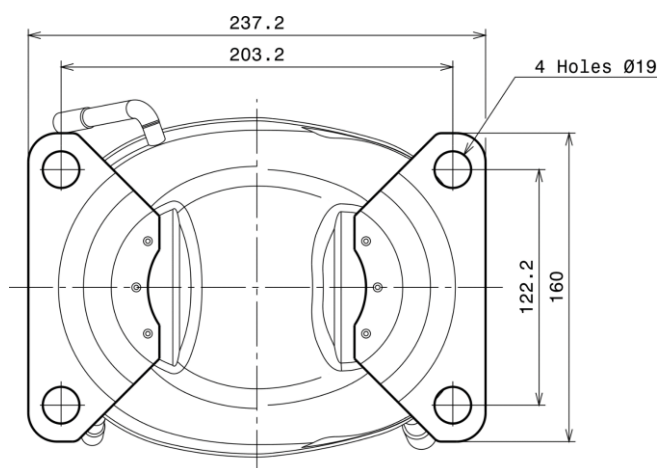
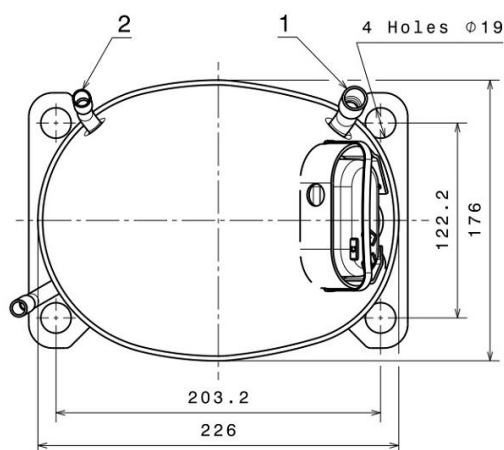

MODEL	WYDAJNOŚĆ DLA CZYNNIKA R404A							
	TEMPERATURA A SKRAPLANIA	TEMPERATURA ODPAROWANIA						
		-15°C	-10°C	-5°C	0°C	5°C	7,2°C	10°C
		W	W	W	W	W	W	W
MS34TB-T	55°C	1 850	2 357	2 919	3 535	4 205	4 517	4 930
	45°C	2 379	3 002	3 680	4 412	5 198	5 562	6 039

MODEL	POJEMNOŚĆ [CM ³]	ZASILANIE [V]	TYP SILNIKA	RODZAJ ROZRUCHU	LRA [A]	OLEJ		WAGA NETTO [KG]
						RODZAJ	IŁOŚĆ [ML]	
MS34TB-T	34,42	220-240	CSR	HST	41,0	POE46	700	21,76

LRA – PRĄD ROZRUCHU

CSR – KONDENSATOR STARTU I PRACY

HST – WYSOKI MOMENT ROZRUCHOWY SILNIKA, MOŻLIWA PRACA Z ZAWOREM ROZPRĘŻNYM LUB KAPILARĄ