



Condensing unit
Voltage Code : TZ

TAGT4573ZHR-TZ

High Temp. Commercial (HP)

400V 3~ 50Hz / 440V 3~ 60 Hz

R452A / R404A / R448A / R449A

TAGT4573ZHR-TZ

Conditions	Frequency	Nominal Cooling Capacity		Sound Power ISO3745 / ISO 3743-1
		Watts	BTU/h	
EN13215 / R452A	50 Hz / 60 Hz	10182 / 11785	34722 / 40188	85 dBA
EN13215 / R404A	50 Hz / 60 Hz	10468 / 12106	35696 / 41280	85 dBA
EN13215 / R448A	50 Hz / 60 Hz	8987 / 10476	30645 / 35722	85 dBA
EN13215 / R449A	50 Hz / 60 Hz	8992 / 10480	30662 / 35735	85 dBA

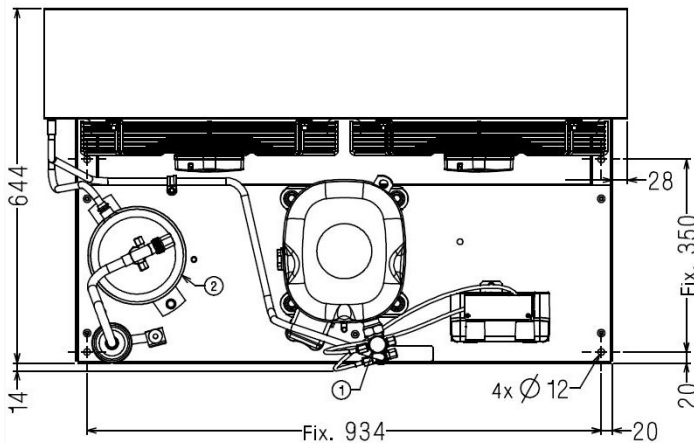
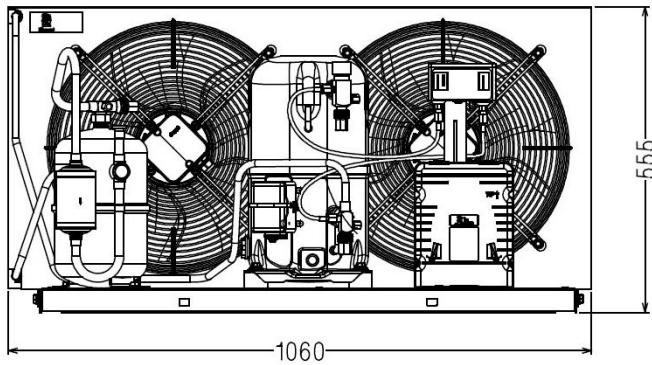

* EN13215 : T°Ambient 32.0°C / T°Evap. -10.0°C / T°Return gas temp.. 20.0°C
T°Subcooling. 3.0K

Net Weight (Kg)	107.0
Expansion device	Expansion_Valve
Air Flow (m³/h)	6000 / 6800
Compo Data Sheet	227LU-T
Elec Comp Type	TRI
Current (Amp)	
Load Rated Amp	14 16.2
Max Cont Current	21.3 21.3
Lock Rotor Amp	62 67
Fan	
Speed (rpm)	1360 / 1520
Power (W)	280.0
Diameter (mm)	420
Protection	Overload
IP Level	IP54
Condenser	B420P/45000
Liquid Receiver	
Capacity (L)	6.0
Maximum Pressure (Bars)	32.0
Suction Line	
Suction Type	Vanne Orientable
For Tubing Out Diam	28.6 (1"1/8)
Suction Connection Type	Brased
Liquid Line	
Liquid Line Type	Vanne Orientable
For Tubing Out Diam	15.9 (5/8")
Liquid Connecton Type	Brased
Connection Type	VR
Fan Guard	maille < à 8mm

Note : Tecumseh reserves the right to change information contained in this document without notification.



Tecumseh

TAGT4573ZHR-TZ	Tension TZ : 400V 3~ 50Hz / 440V 3~ 60 Hz
-----------------------	--

Les performances sont données dans les conditions EN13215 :	Gaz aspirés :	20.0 °C
Condition Dew	Sous refroidissement :	3.0 K
The performance data are in EN13215 conditions :	Return gas :	20.0 °C
Dew Condition	Subcooling :	3.0 K

50 Hz R452A											
											N°6722
5 T ambience	6 T évaporation	(°C)	-25	-20	-15	-10	-5	0	5	10	15
25	1 P frigorifique	(Watt)	5578	7305	9226	11331	13595	15990	18502	21149	24003
	2 P absorbée	(W)	3295	3758	4250	4786	5375	6025	6740	7521	8367
	3 I absorbée	(A)	7.93	8.55	9.23	9.99	10.8	11.8	12.9	14.0	15.3
	4 Tc	(°C)	26.6	27.4	28.8	30.8	33.3	36.1	39.1	42.1	45.0
32	1 P frigorifique	(Watt)		6387	8211	10182	12282	14491	16803	19248	21907
	2 P absorbée	(W)		3799	4326	4890	5501	6168	6896	7689	8545
	3 I absorbée	(A)		8.62	9.35	10.2	11.0	12.0	13.1	14.2	15.5
	4 Tc	(°C)		33.7	34.8	36.5	38.7	41.2	43.9	46.7	49.4
43	1 P frigorifique	(Watt)			6510	8269	10118	12050	14075	16241	18662
	2 P absorbée	(W)			4350	4968	5622	6323	7079	7895	8772
	3 I absorbée	(A)			9.40	10.3	11.2	12.2	13.3	14.5	15.8
	4 Tc	(°C)			44.4	45.6	47.3	49.3	51.6	53.9	56.2

60 Hz R452A											
											N°6722
5 T ambience	6 T évaporation	(°C)	-25	-20	-15	-10	-5	0	5	10	15
25	1 P frigorifique	(Watt)	6556	8571	10773	13149	15672	18312	21054	23923	27007
	2 P absorbée	(W)	4385	5001	5655	6362	7135	7984	8916	9935	11039
	3 I absorbée	(A)	9.38	10.3	11.2	12.2	13.3	14.5	15.8	17.2	18.7
	4 Tc	(°C)	29.8	30.5	31.8	33.7	36.1	38.8	41.7	44.6	47.4
32	1 P frigorifique	(Watt)		7482	9567	11785	14117	16540	19052	21689	24558
	2 P absorbée	(W)		5035	5727	6467	7270	8145	9099	10138	11260
	3 I absorbée	(A)		10.3	11.3	12.4	13.5	14.8	16.1	17.5	19.0
	4 Tc	(°C)		37.0	38.0	39.6	41.7	44.2	46.8	49.4	52.0
43	1 P frigorifique	(Watt)			7612	9584	11624	13727	15912	18245	20885
	2 P absorbée	(W)			5789	6580	7429	8346	9339	10411	11565
	3 I absorbée	(A)			11.3	12.5	13.7	15.0	16.4	17.8	19.4
	4 Tc	(°C)			48.0	49.1	50.7	52.6	54.8	57.0	59.2

1 = cooling capacity 2 = power input 3 = current 4 = condensing temperature 5 = ambient temperature 6 = evaporating temperature

Nota : Tecumseh se réserve le droit de modifier les informations contenues dans ce document sans préavis.

Note : Tecumseh reserves the right to change information contained in this document without notification.

© 2021 Tecumseh Products Company
All rights reserved



Tecumseh

TAGT4573ZHR-TZ	Tension TZ : 400V 3~ 50Hz / 440V 3~ 60 Hz
-----------------------	--

Les performances sont données dans les conditions EN13215 :	Gaz aspirés :	20.0 °C
Condition Dew	Sous refroidissement :	3.0 K
The performance data are in EN13215 conditions :	Return gas :	20.0 °C
Dew Condition	Subcooling :	3.0 K

50 Hz R404A											
N°6721											
5 T ambience	6 T évaporation	(°C)	-25	-20	-15	-10	-5	0	5	10	15
25	1 P frigorifique	(Watt)	6077	7758	9629	11667	13841	16117	18474	20916	23493
	2 P absorbée	(W)	3462	3942	4454	5010	5615	6273	6988	7760	8588
	3 I absorbée	(A)	8.25	8.89	9.59	10.4	11.3	12.2	13.3	14.4	15.6
	4 Tc	(°C)	29.2	30.5	32.4	34.7	37.2	40.0	43.0	45.9	48.8
32	1 P frigorifique	(Watt)	5246	6848	8594	10468	12446	14504	16632	18846	21214
	2 P absorbée	(W)	3479	3994	4537	5117	5743	6418	7146	7928	8763
	3 I absorbée	(A)	8.28	8.97	9.72	10.5	11.4	12.4	13.5	14.6	15.8
	4 Tc	(°C)	35.3	36.5	38.1	40.2	42.6	45.1	47.8	50.5	53.2
43	1 P frigorifique	(Watt)		5357	6900	8514	10187	11910	13690	15566	17634
	2 P absorbée	(W)		3986	4580	5205	5868	6575	7329	8133	8986
	3 I absorbée	(A)		8.98	9.81	10.7	11.6	12.7	13.8	14.9	16.2
	4 Tc	(°C)		45.7	47.1	48.9	50.9	53.2	55.5	57.8	60.1

60 Hz R404A											
N°6721											
5 T ambience	6 T évaporation	(°C)	-25	-20	-15	-10	-5	0	5	10	15
25	1 P frigorifique	(Watt)	7151	9105	11238	13527	15934	18425	20976	23595	26346
	2 P absorbée	(W)	4612	5247	5924	6654	7445	8304	9235	10241	11322
	3 I absorbée	(A)	9.75	10.7	11.7	12.7	13.8	15.0	16.3	17.7	19.1
	4 Tc	(°C)	32.4	33.6	35.3	37.5	40.0	42.7	45.5	48.4	51.1
32	1 P frigorifique	(Watt)		8022	10009	12106	14286	16523	18808	21164	23676
	2 P absorbée	(W)		5295	6006	6767	7586	8470	9422	10446	11541
	3 I absorbée	(A)		10.7	11.8	12.9	14.0	15.3	16.6	17.9	19.4
	4 Tc	(°C)		39.7	41.2	43.2	45.5	48.0	50.6	53.2	55.7
43	1 P frigorifique	(Watt)			8058	9855	11680	13528	15411	17384	
	2 P absorbée	(W)			6094	6898	7759	8682	9670	10724	
	3 I absorbée	(A)			11.7	12.9	14.2	15.5	16.9	18.3	
	4 Tc	(°C)			50.5	52.2	54.1	56.3	58.5	60.7	

1 = cooling capacity 2 = power input 3 = current 4 = condensing temperature 5 = ambient temperature 6 = evaporating temperature

Nota : Tecumseh se réserve le droit de modifier les informations contenues dans ce document sans préavis.

Note : Tecumseh reserves the right to change information contained in this document without notification.

© 2021 Tecumseh Products Company
All rights reserved



Tecumseh

TAGT4573ZHR-TZ	Tension TZ : 400V 3~ 50Hz / 440V 3~ 60 Hz
-----------------------	--

Les performances sont données dans les conditions EN13215 :	Gaz aspirés :	20.0 °C
Condition Dew	Sous refroidissement :	3.0 K
The performance data are in EN13215 conditions :	Return gas :	20.0 °C
Dew Condition	Subcooling :	3.0 K

© 2021 Tecumseh Products Company
All rights reserved

50 Hz R448A (*)

N°7049

5 T ambience	6 T évaporation	(°C)	-25	-20	-15	-10	-5	0	5	10	15
25	1 P frigorifique	(Watt)	4671	6206	7984	10010	12278	14773	17465	20308	23252
	2 P absorbée	(W)	3118	3563	4047	4573	5146	5773	6464	7230	8085
	3 I absorbée	(A)	7.59	8.19	8.87	9.62	10.4	11.4	12.4	13.5	14.8
	4 Tc	(°C)	27.4	29.0	30.8	32.8	35.0	37.5	40.2	43.2	46.5
32	1 P frigorifique	(Watt)		5436	7101	8987	11093	13409	15912	18566	21329
	2 P absorbée	(W)		3598	4111	4666	5268	5922	6638	7426	8297
	3 I absorbée	(A)		8.26	8.97	9.76	10.6	11.6	12.6	13.8	15.1
	4 Tc	(°C)		35.1	36.7	38.5	40.6	42.8	45.3	48.1	51.2
43	1 P frigorifique	(Watt)			5682	7346	9199	11238	13452	15818	
	2 P absorbée	(W)			4122	4732	5386	6090	6851	7678	
	3 I absorbée	(A)			9.01	9.88	10.8	11.9	13.0	14.2	
	4 Tc	(°C)			46.0	47.6	49.3	51.2	53.4	55.8	

60 Hz R448A (*)

N°7049

5 T ambience	6 T évaporation	(°C)	-25	-20	-15	-10	-5	0	5	10	15
25	1 P frigorifique	(Watt)		7310	9358	11658	14204	16972	19920	22981	26061
	2 P absorbée	(W)		4741	5371	6054	6796	7602	8482	9445	10506
	3 I absorbée	(A)		9.86	10.8	11.8	12.8	13.9	15.2	16.5	17.9
	4 Tc	(°C)		32.8	34.6	36.6	38.9	41.4	44.3	47.6	51.2
32	1 P frigorifique	(Watt)		6409	8333	10476	12837	15400	18132	20977	23853
	2 P absorbée	(W)		4784	5448	6168	6950	7798	8719	9723	10823
	3 I absorbée	(A)		9.87	10.9	11.9	13.0	14.2	15.5	16.9	18.3
	4 Tc	(°C)		39.0	40.6	42.4	44.4	46.8	49.4	52.4	55.7
43	1 P frigorifique	(Watt)				8637	10714	12964	15367		
	2 P absorbée	(W)				6296	7140	8054	9042		
	3 I absorbée	(A)				12.0	13.2	14.5	15.9		
	4 Tc	(°C)				51.5	53.2	55.1	57.3		

1 = cooling capacity 2 = power input 3 = current 4 = condensing temperature 5 = ambient temperature 6 = evaporating temperature

(*) Veuillez vous référer strictement aux Recommandations d'Utilisation et Bulletins Marketing Tecumseh du fait de la température de reflux élevée pour les applications LBP.

(*) Due to very high discharge temperature especially on LBP conditions, please strictly refer to Tecumseh Guidelines & Marketing Bulletin when using this refrigerant.

Nota : Tecumseh se réserve le droit de modifier les informations contenues dans ce document sans préavis.

Note : Tecumseh reserves the right to change information contained in this document without notification.



Tecumseh

TAGT4573ZHR-TZ	Tension TZ : 400V 3~ 50Hz / 440V 3~ 60 Hz
-----------------------	--

Les performances sont données dans les conditions EN13215 :	Gaz aspirés :	20.0 °C
Condition Dew	Sous refroidissement :	3.0 K
The performance data are in EN13215 conditions :	Return gas :	20.0 °C
Dew Condition	Subcooling :	3.0 K

50 Hz R449A (*)											
											N°6821
5 T ambience	6 T évaporation	(°C)	-25	-20	-15	-10	-5	0	5	10	15
25	1 P frigorifique	(Watt)	4673	6209	7988	10015	12286	14783	17477	20324	23271
	2 P absorbée	(W)	3118	3563	4047	4573	5146	5773	6464	7230	8085
	3 I absorbée	(A)	7.59	8.19	8.87	9.62	10.4	11.4	12.4	13.5	14.8
	4 Tc	(°C)	27.4	29.1	30.9	32.8	35.0	37.5	40.2	43.2	46.5
32	1 P frigorifique	(Watt)		5438	7105	8992	11100	13417	15922	18579	21344
	2 P absorbée	(W)		3598	4111	4666	5268	5922	6638	7426	8297
	3 I absorbée	(A)		8.26	8.97	9.76	10.6	11.6	12.6	13.8	15.1
	4 Tc	(°C)		35.1	36.7	38.5	40.6	42.8	45.3	48.1	51.1
43	1 P frigorifique	(Watt)			5685	7350	9204	11244	13459	15827	
	2 P absorbée	(W)			4122	4732	5386	6090	6851	7678	
	3 I absorbée	(A)			9.01	9.88	10.8	11.9	13.0	14.2	
	4 Tc	(°C)			46.0	47.5	49.2	51.2	53.3	55.7	

60 Hz R449A (*)											
											N°6821
5 T ambience	6 T évaporation	(°C)	-25	-20	-15	-10	-5	0	5	10	15
25	1 P frigorifique	(Watt)		7313	9361	11662	14209	16977	19925	22986	26067
	2 P absorbée	(W)		4741	5371	6054	6796	7602	8482	9445	10506
	3 I absorbée	(A)		9.86	10.8	11.8	12.8	13.9	15.2	16.5	17.9
	4 Tc	(°C)		32.8	34.6	36.6	38.9	41.4	44.3	47.5	51.2
32	1 P frigorifique	(Watt)		6412	8336	10480	12841	15405	18138	20983	23859
	2 P absorbée	(W)		4784	5448	6168	6950	7798	8719	9723	10823
	3 I absorbée	(A)		9.87	10.9	11.9	13.0	14.2	15.5	16.9	18.3
	4 Tc	(°C)		39.0	40.6	42.4	44.4	46.7	49.3	52.3	55.7
43	1 P frigorifique	(Watt)				8640	10718	12969	15373		
	2 P absorbée	(W)				6296	7140	8054	9042		
	3 I absorbée	(A)				12.0	13.2	14.5	15.9		
	4 Tc	(°C)				51.4	53.1	55.0	57.3		

1 = cooling capacity 2 = power input 3 = current 4 = condensing temperature 5 = ambient temperature 6 = evaporating temperature

(*) Veuillez vous référer strictement aux Recommandations d'Utilisation et Bulletins Marketing Tecumseh du fait de la température de reflux élevée pour les applications LBP.

(*) Due to very high discharge temperature especially on LBP conditions, please strictly refer to Tecumseh Guidelines & Marketing Bulletin when using this refrigerant.

Nota : Tecumseh se réserve le droit de modifier les informations contenues dans ce document sans préavis.

Note : Tecumseh reserves the right to change information contained in this document without notification.

© 2021 Tecumseh Products Company
All rights reserved