

Condensing unit
Voltage Code : TZ

TAJN9510ZMHR-TZ

High Temp. Commercial (MHP)

400V 3~ 50Hz / 440V 3~ 60 Hz

R452A / R404A / R448A / R449A

TAJN9510ZMHR-TZ

Conditions	Frequency	Nominal Cooling Capacity		Sound Power ISO3745 / ISO 3743-1
		Watts	BTU/h	
EN13215 / R452A	50 Hz / 60 Hz	1396 / 1583	4761 / 5399	67 dBA
EN13215 / R404A	50 Hz / 60 Hz	1462 / 1659	4986 / 5658	67 dBA
EN13215 / R448A	50 Hz / 60 Hz	1285 / 1461	4382 / 4982	67 dBA
EN13215 / R449A	50 Hz / 60 Hz	1286 / 1462	4384 / 4985	67 dBA

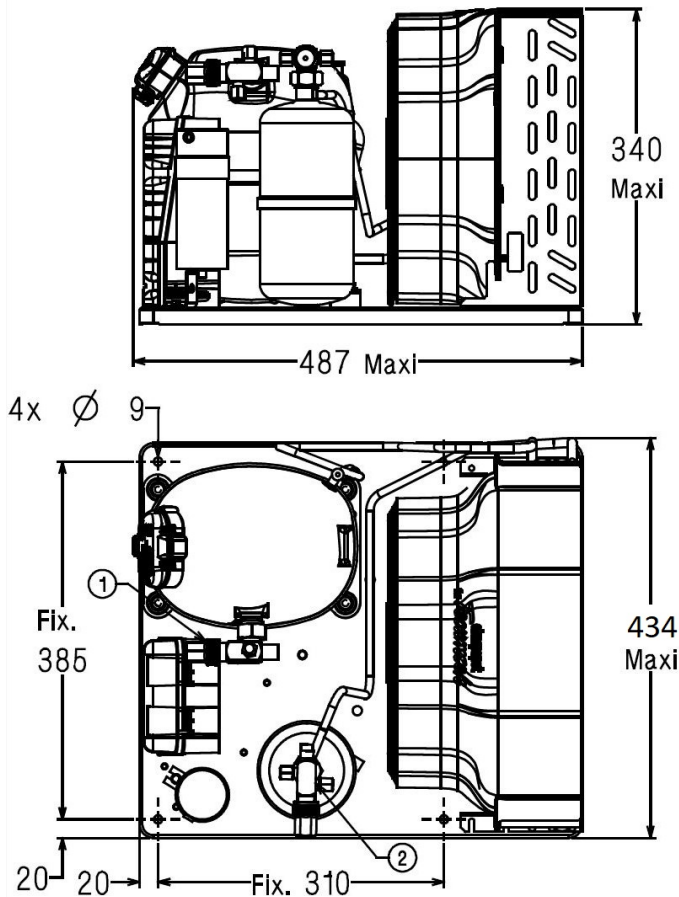

Net Weight (Kg)	31.0
Expansion device	Expansion_Valve
Air Flow (m³/h)	900 / 900
Compo Data Sheet	224EU-TZ
Elec Comp Type	TRI
Current (Amp)	
Load Rated Amp	2.3 2.5
Max Cont Current	3.2 3.2
Lock Rotor Amp	14.7 14.7
Fan	
Speed (rpm)	1200 / 1200
Power (W)	22.0
Diameter (mm)	300
Protection	Overload
IP Level	IP54
Condenser	M300/3900
Liquid Receiver	
Capacity (L)	1.5
Maximum Pressure (Bars)	32.0
Suction Line	
Suction Type	Vanne Orientable
For Tubing Out Diam	15.9 (5/8")
Suction Connection Type	Brased
Liquid Line	
Liquid Line Type	Vanne Orientable
For Tubing Out Diam	9.5 (3/8")
Liquid Connecton Type	Brased
Heat recovery pipes	
Component/ Type of connexion	NA
For tube Outside diameter :	NA

* EN13215 : T°Ambient 32.0°C / T°Evap. -10.0°C / T°Return gas temp.. 20.0°C
T°Subcooling. 3.0K



Tecumseh

TAJN9510ZMHR-TZ	Tension TZ : 400V 3~ 50Hz / 440V 3~ 60 Hz
------------------------	--

Les performances sont données dans les conditions EN13215 :	Gaz aspirés :	20.0 °C
Condition Dew	Sous refroidissement :	3.0 K
The performance data are in EN13215 conditions :	Return gas :	20.0 °C
Dew Condition	Subcooling :	3.0 K

50 Hz R452A											
											N°6293
5 T ambience	6 T évaporation	(°C)	-25	-20	-15	-10	-5	0	5	10	15
25	1 P frigorifique	(Watt)	840	1055	1295	1558	1843	2145	2461	2788	3122
	2 P absorbée	(W)	587	666	748	834	923	1018	1119	1226	1342
	3 I absorbée	(A)	1.52	1.61	1.70	1.81	1.93	2.06	2.21	2.38	2.56
	4 Tc	(°C)	31.5	33.7	36.0	38.4	40.9	43.6	46.3	49.2	52.2
32	1 P frigorifique	(Watt)	730	933	1156	1396	1652	1922	2202	2490	2786
	2 P absorbée	(W)	589	678	768	862	960	1063	1172	1288	1412
	3 I absorbée	(A)	1.50	1.61	1.72	1.84	1.98	2.12	2.29	2.46	2.66
	4 Tc	(°C)	37.4	39.5	41.7	44.0	46.4	48.9	51.5	54.3	57.1
43	1 P frigorifique	(Watt)		735	930	1135	1348	1569	1795		
	2 P absorbée	(W)		678	785	894	1008	1125	1249		
	3 I absorbée	(A)		1.59	1.73	1.88	2.04	2.21	2.39		
	4 Tc	(°C)		48.7	50.7	52.8	55.0	57.4	59.8		

60 Hz R452A											
											N°6293
5 T ambience	6 T évaporation	(°C)	-25	-20	-15	-10	-5	0	5	10	15
25	1 P frigorifique	(Watt)	919	1187	1473	1774	2087	2408	2733	3058	3383
	2 P absorbée	(W)	706	815	927	1046	1172	1309	1458	1622	1802
	3 I absorbée	(A)	1.47	1.59	1.73	1.89	2.05	2.24	2.44	2.67	2.91
	4 Tc	(°C)	33.1	35.6	38.2	40.9	43.7	46.6	49.6	52.7	55.9
32	1 P frigorifique	(Watt)	774	1035	1305	1583	1867	2153	2440	2724	
	2 P absorbée	(W)	697	817	941	1071	1209	1357	1516	1690	
	3 I absorbée	(A)	1.45	1.59	1.74	1.91	2.09	2.29	2.51	2.74	
	4 Tc	(°C)	38.7	41.1	43.6	46.2	48.9	51.7	54.6	57.6	
43	1 P frigorifique	(Watt)		793	1038	1281	1519	1754			
	2 P absorbée	(W)		798	944	1095	1253	1421			
	3 I absorbée	(A)		1.57	1.75	1.94	2.15	2.37			
	4 Tc	(°C)		49.9	52.2	54.7	57.2	59.9			

1 = cooling capacity 2 = power input 3 = current 4 = condensing temperature 5 = ambient temperature 6 = evaporating temperature

Nota : Tecumseh se réserve le droit de modifier les informations contenues dans ce document sans préavis.

Note : Tecumseh reserves the right to change information contained in this document without notification.

© 2025 Tecumseh Products Company
All rights reserved



Tecumseh

TAJN9510ZMHR-TZ	Tension TZ : 400V 3~ 50Hz / 440V 3~ 60 Hz
------------------------	--

Les performances sont données dans les conditions EN13215 :	Gaz aspirés :	20.0 °C
Condition Dew	Sous refroidissement :	3.0 K
The performance data are in EN13215 conditions :	Return gas :	20.0 °C
Dew Condition	Subcooling :	3.0 K

50 Hz R404A											
											N°5067
5 T ambience	6 T évaporation	(°C)	-25	-20	-15	-10	-5	0	5	10	15
25	1 P frigorifique	(Watt)	913	1129	1370	1632	1912	2205	2507	2813	3119
	2 P absorbée	(W)	621	702	785	870	959	1052	1149	1253	1363
	3 I absorbée	(A)	1.61	1.69	1.78	1.89	2.00	2.13	2.27	2.43	2.60
	4 Tc	(°C)	34.3	36.5	38.7	41.1	43.5	46.1	48.7	51.4	54.3
32	1 P frigorifique	(Watt)	797	1002	1224	1462	1712	1971	2235	2501	2765
	2 P absorbée	(W)	628	717	808	902	999	1100	1205	1316	1434
	3 I absorbée	(A)	1.60	1.69	1.80	1.92	2.05	2.19	2.35	2.52	2.70
	4 Tc	(°C)	40.1	42.1	44.2	46.5	48.8	51.2	53.7	56.3	58.9
43	1 P frigorifique	(Watt)		795	990	1190	1395	1602	1809		
	2 P absorbée	(W)		725	832	940	1052	1167	1287		
	3 I absorbée	(A)		1.69	1.83	1.97	2.12	2.29	2.46		
	4 Tc	(°C)		51.0	52.9	54.9	57.0	59.2	61.4		

60 Hz R404A											
											N°5067
5 T ambience	6 T évaporation	(°C)	-25	-20	-15	-10	-5	0	5	10	15
25	1 P frigorifique	(Watt)	1004	1275	1561	1859	2164	2472	2777	3075	3364
	2 P absorbée	(W)	750	860	974	1093	1219	1354	1500	1659	1832
	3 I absorbée	(A)	1.55	1.68	1.82	1.97	2.13	2.32	2.51	2.73	2.96
	4 Tc	(°C)	35.9	38.4	40.9	43.5	46.2	49.0	51.8	54.8	57.8
32	1 P frigorifique	(Watt)	852	1115	1385	1659	1934	2205	2470	2724	2969
	2 P absorbée	(W)	746	867	992	1122	1259	1405	1561	1730	1913
	3 I absorbée	(A)	1.54	1.68	1.83	2.00	2.18	2.37	2.58	2.81	3.05
	4 Tc	(°C)	41.4	43.7	46.1	48.6	51.2	53.9	56.6	59.4	62.3
43	1 P frigorifique	(Watt)		862	1106	1343	1571	1788			
	2 P absorbée	(W)		857	1003	1154	1311	1475			
	3 I absorbée	(A)		1.67	1.85	2.04	2.24	2.46			
	4 Tc	(°C)		52.1	54.3	56.7	59.1	61.5			

1 = cooling capacity 2 = power input 3 = current 4 = condensing temperature 5 = ambient temperature 6 = evaporating temperature

Nota : Tecumseh se réserve le droit de modifier les informations contenues dans ce document sans préavis.

Note : Tecumseh reserves the right to change information contained in this document without notification.

© 2025 Tecumseh Products Company
All rights reserved



Tecumseh

TAJN9510ZMHR-TZ	Tension TZ : 400V 3~ 50Hz / 440V 3~ 60 Hz
------------------------	--

Les performances sont données dans les conditions EN13215 :	Gaz aspirés :	20.0 °C
Condition Dew	Sous refroidissement :	3.0 K
The performance data are in EN13215 conditions :	Return gas :	20.0 °C
Dew Condition	Subcooling :	3.0 K

© 2025 Tecumseh Products Company
All rights reserved

50 Hz R448A (*)

N°6983

5 T ambience	6 T évaporation	(°C)	-25	-20	-15	-10	-5	0	5	10	15
25	1 P frigorifique	(Watt)		924	1162	1426	1717	2034	2376	2742	3129
	2 P absorbée	(W)		629	709	794	883	979	1082	1193	1312
	3 I absorbée	(A)		1.52	1.61	1.72	1.84	1.98	2.14	2.31	2.50
	4 Tc	(°C)		34.1	36.4	38.8	41.4	44.0	46.8	49.7	52.7
32	1 P frigorifique	(Watt)			1040	1285	1553	1843	2155	2488	
	2 P absorbée	(W)			729	822	921	1026	1138	1258	
	3 I absorbée	(A)			1.63	1.76	1.90	2.05	2.22	2.40	
	4 Tc	(°C)			42.1	44.4	46.9	49.4	52.0	54.7	
43	1 P frigorifique	(Watt)				1063	1296				
	2 P absorbée	(W)				855	970				
	3 I absorbée	(A)				1.80	1.96				
	4 Tc	(°C)				53.3	55.5				

60 Hz R448A (*)

N°6983

5 T ambience	6 T évaporation	(°C)	-25	-20	-15	-10	-5	0	5	10	15
25	1 P frigorifique	(Watt)		1037	1321	1626	1952	2297	2661	3041	3438
	2 P absorbée	(W)		768	877	995	1122	1261	1413	1581	1767
	3 I absorbée	(A)		1.51	1.64	1.80	1.97	2.16	2.37	2.60	2.85
	4 Tc	(°C)		36.0	38.6	41.4	44.2	47.1	50.1	53.2	56.4
32	1 P frigorifique	(Watt)			1174	1461	1764	2081	2413		
	2 P absorbée	(W)			892	1021	1160	1310	1475		
	3 I absorbée	(A)			1.66	1.83	2.01	2.22	2.44		
	4 Tc	(°C)			44.1	46.7	49.4	52.2	55.1		
43	1 P frigorifique	(Watt)				1205					
	2 P absorbée	(W)				1044					
	3 I absorbée	(A)				1.86					
	4 Tc	(°C)				55.2					

1 = cooling capacity 2 = power input 3 = current 4 = condensing temperature 5 = ambient temperature 6 = evaporating temperature

(*) Veuillez vous référer strictement aux Recommandations d'Utilisation et Bulletins Marketing Tecumseh du fait de la température de reflux élevée pour les applications LBP.

(*) Due to very high discharge temperature especially on LBP conditions, please strictly refer to Tecumseh Guidelines & Marketing Bulletin when using this refrigerant.

Nota : Tecumseh se réserve le droit de modifier les informations contenues dans ce document sans préavis.

Note : Tecumseh reserves the right to change information contained in this document without notification.



Tecumseh

TAJN9510ZMHR-TZ	Tension TZ : 400V 3~ 50Hz / 440V 3~ 60 Hz
------------------------	--

Les performances sont données dans les conditions EN13215 :	Gaz aspirés :	20.0 °C
Condition Dew	Sous refroidissement :	3.0 K
The performance data are in EN13215 conditions :	Return gas :	20.0 °C
Dew Condition	Subcooling :	3.0 K

50 Hz R449A (*)											
											N°6225
5 T ambience	6 T évaporation	(°C)	-25	-20	-15	-10	-5	0	5	10	15
25	1 P frigorifique	(Watt)		925	1162	1427	1718	2035	2378	2743	3131
	2 P absorbée	(W)		629	709	794	883	979	1082	1193	1312
	3 I absorbée	(A)		1.52	1.61	1.72	1.84	1.98	2.14	2.31	2.50
	4 Tc	(°C)		34.1	36.4	38.8	41.4	44.0	46.8	49.6	52.6
32	1 P frigorifique	(Watt)			1040	1286	1554	1844	2156	2490	
	2 P absorbée	(W)			729	822	921	1026	1138	1258	
	3 I absorbée	(A)			1.63	1.76	1.90	2.05	2.22	2.40	
	4 Tc	(°C)			42.1	44.4	46.8	49.3	51.9	54.7	
43	1 P frigorifique	(Watt)				1064	1297				
	2 P absorbée	(W)				855	970				
	3 I absorbée	(A)				1.80	1.96				
	4 Tc	(°C)				53.3	55.4				

60 Hz R449A (*)											
											N°6225
5 T ambience	6 T évaporation	(°C)	-25	-20	-15	-10	-5	0	5	10	15
25	1 P frigorifique	(Watt)		1037	1321	1627	1953	2299	2662	3043	3439
	2 P absorbée	(W)		768	877	995	1122	1261	1413	1581	1767
	3 I absorbée	(A)		1.51	1.64	1.80	1.97	2.16	2.37	2.60	2.85
	4 Tc	(°C)		36.0	38.6	41.4	44.2	47.0	50.0	53.1	56.3
32	1 P frigorifique	(Watt)			1175	1462	1764	2082	2414		
	2 P absorbée	(W)			892	1021	1160	1310	1475		
	3 I absorbée	(A)			1.66	1.83	2.01	2.22	2.44		
	4 Tc	(°C)			44.1	46.7	49.4	52.2	55.0		
43	1 P frigorifique	(Watt)				1206					
	2 P absorbée	(W)				1044					
	3 I absorbée	(A)				1.86					
	4 Tc	(°C)				55.1					

1 = cooling capacity 2 = power input 3 = current 4 = condensing temperature 5 = ambient temperature 6 = evaporating temperature

(*) Veuillez vous référer strictement aux Recommandations d'Utilisation et Bulletins Marketing Tecumseh du fait de la température de reflux élevée pour les applications LBP.
 (*) Due to very high discharge temperature especially on LBP conditions, please strictly refer to Tecumseh Guidelines & Marketing Bulletin when using this refrigerant.

Nota : Tecumseh se réserve le droit de modifier les informations contenues dans ce document sans préavis.
Note : Tecumseh reserves the right to change information contained in this document without notification.

© 2025 Tecumseh Products Company
All rights reserved