



Condensing unit
Voltage Code : TZ

TAGT2516ZBR-TZ

Low Temp. Commercial (BP)

400V 3~ 50Hz / 440V 3~ 60 Hz

R452A / R404A / R448A / R449A

TAGT2516ZBR-TZ

Conditions	Frequency	Nominal Cooling Capacity		Sound Power ISO3745 / ISO 3743-1
		Watts	BTU/h	
Standard TE / R452A	50 Hz / 60 Hz	4323 / 4760	14740 / 16232	81 dBA
Standard TE / R404A	50 Hz / 60 Hz	4846 / 5338	16523 / 18204	81 dBA
Standard TE / R448A	50 Hz / 60 Hz	3771 / 4176	12860 / 14239	81 dBA
Standard TE / R449A	50 Hz / 60 Hz	3776 / 4181	12877 / 14258	81 dBA

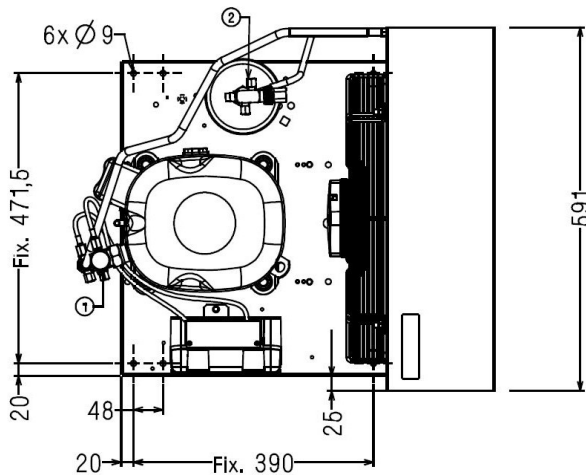
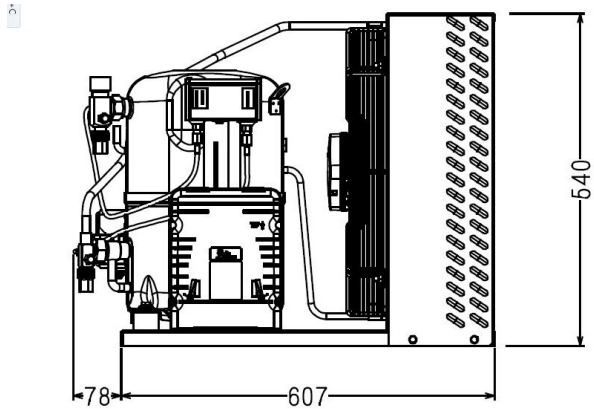

* Standard TE : T°Ambient 32.0°C / T°Evap. -23.3°C / T°Return gas temp.. 32.0°C
T°Subcooling. 2.0K

Net Weight (Kg)	79.0
Expansion device	Expansion_Valve
Air Flow (m³/h)	3300 / 3650
Compo Data Sheet	2564
Elec Comp Type	TRI
Current (Amp)	
Load Rated Amp	5.6 5.7
Max Cont Current	10.2 10.3
Lock Rotor Amp	43 43
Fan	
Speed (rpm)	1360 / 1520
Power (W)	280.0
Diameter (mm)	420
Protection	Overload
IP Level	IP54
Condenser	M420/24000
Liquid Receiver	
Capacity (L)	2.35
Maximum Pressure (Bars)	32.0
Suction Line	
Suction Type	Vanne Orientable
For Tubing Out Diam	22.2 (7/8")
Suction Connection Type	Brased
Liquid Line	
Liquid Line Type	Vanne Orientable
For Tubing Out Diam	9.5 (3/8")
Liquid Connecton Type	Brased
Connection Type	VR
Fan Guard	maille < à 8mm

Note : Tecumseh reserves the right to change information contained in this document without notification.



Tecumseh

TAGT2516ZBR-TZ	Tension TZ : 400V 3~ 50Hz / 440V 3~ 60 Hz
-----------------------	--

Les performances sont données dans les conditions Standard TE :	Gaz aspirés :	32.0 °C
Condition Dew	Sous refroidissement :	2.0 K
The performance data are in Standard TE conditions :	Return gas :	32.0 °C
Dew Condition	Subcooling :	2.0 K

50 Hz R452A									
N°6733									
5 T ambience	6 T évaporation	(°C)	-40	-35	-30	-25	-20	-15	-10
25	1 P frigorifique	(Watt)	1683	2502	3463	4559	5783	7125	8586
	2 P absorbée	(W)	1546	1871	2221	2603	3027	3498	4021
	3 I absorbée	(A)	4.27	4.58	4.98	5.48	6.05	6.69	7.37
	4 Tc	(°C)	27.1	28.2	29.8	32.0	34.6	37.4	40.4
32	1 P frigorifique	(Watt)	1306	2067	2951	3955	5073	6300	7640
	2 P absorbée	(W)	1472	1826	2199	2601	3041	3526	4061
	3 I absorbée	(A)	4.18	4.52	4.96	5.49	6.08	6.74	7.44
	4 Tc	(°C)	33.8	34.6	36.0	37.9	40.3	42.9	45.7
43	1 P frigorifique	(Watt)		1395	2153	3009	3962	5014	6176
	2 P absorbée	(W)		1703	2116	2553	3022	3532	4087
	3 I absorbée	(A)		4.39	4.87	5.44	6.06	6.74	7.46
	4 Tc	(°C)		44.8	45.8	47.3	49.3	51.5	54.0

60 Hz R452A									
N°6733									
5 T ambience	6 T évaporation	(°C)	-40	-35	-30	-25	-20	-15	-10
25	1 P frigorifique	(Watt)	1761	2751	3857	5078	6413	7861	9430
	2 P absorbée	(W)	1751	2163	2588	3043	3545	4105	4733
	3 I absorbée	(A)	4.25	4.69	5.16	5.68	6.27	6.95	7.74
	4 Tc	(°C)	32.1	33.0	34.5	36.6	39.0	41.8	44.7
32	1 P frigorifique	(Watt)	1230	2168	3208	4349	5591	6938	8401
	2 P absorbée	(W)	1550	2022	2494	2989	3523	4112	4765
	3 I absorbée	(A)	4.03	4.53	5.05	5.61	6.24	6.96	7.78
	4 Tc	(°C)	39.1	39.8	41.0	42.8	45.1	47.6	50.3
43	1 P frigorifique	(Watt)		1248	2171	3177	4271	5463	6779
	2 P absorbée	(W)		1652	2222	2797	3399	4046	4751
	3 I absorbée	(A)		4.12	4.74	5.39	6.10	6.88	7.76
	4 Tc	(°C)		50.5	51.4	52.8	54.6	56.8	59.1

1 = cooling capacity 2 = power input 3 = current 4 = condensing temperature 5 = ambient temperature 6 = evaporating temperature

Nota : Tecumseh se réserve le droit de modifier les informations contenues dans ce document sans préavis.

Note : Tecumseh reserves the right to change information contained in this document without notification.

© 2021 Tecumseh Products Company
All rights reserved



Tecumseh

TAGT2516ZBR-TZ	Tension TZ : 400V 3~ 50Hz / 440V 3~ 60 Hz
-----------------------	--

Les performances sont données dans les conditions Standard TE :	Gaz aspirés :	32.0 °C
Condition Dew	Sous refroidissement :	2.0 K
The performance data are in Standard TE conditions :	Return gas :	32.0 °C
Dew Condition	Subcooling :	2.0 K

50 Hz R404A									
N°6728									
5 T ambience	6 T évaporation	(°C)	-40	-35	-30	-25	-20	-15	-10
25	1 P frigorifique	(Watt)	2042	2917	3946	5116	6412	7815	9308
	2 P absorbée	(W)	1661	2004	2371	2768	3202	3678	4201
	3 I absorbée	(A)	4.70	4.94	5.31	5.79	6.42	7.17	8.06
	4 Tc	(°C)	27.4	29.0	31.0	33.2	35.8	38.5	41.5
32	1 P frigorifique	(Watt)	1648	2454	3393	4457	5634	6909	8271
	2 P absorbée	(W)	1612	1976	2362	2777	3228	3720	4259
	3 I absorbée	(A)	4.59	4.89	5.30	5.83	6.49	7.28	8.21
	4 Tc	(°C)	33.8	35.2	37.0	39.1	41.5	44.0	46.8
43	1 P frigorifique	(Watt)	1045	1740	2538	3436	4426	5502	6660
	2 P absorbée	(W)	1486	1883	2303	2749	3230	3750	4315
	3 I absorbée	(A)	4.37	4.76	5.26	5.87	6.60	7.45	8.43
	4 Tc	(°C)	43.8	45.0	46.6	48.4	50.5	52.7	55.1

60 Hz R404A									
N°6728									
5 T ambience	6 T évaporation	(°C)	-40	-35	-30	-25	-20	-15	-10
25	1 P frigorifique	(Watt)	2216	3244	4410	5702	7102	8594	10162
	2 P absorbée	(W)	1931	2343	2778	3247	3760	4326	4954
	3 I absorbée	(A)	4.53	4.97	5.44	5.98	6.58	7.26	8.05
	4 Tc	(°C)	32.3	33.7	35.6	37.7	40.1	42.7	45.5
32	1 P frigorifique	(Watt)	1648	2618	3709	4908	6203	7580	9027
	2 P absorbée	(W)	1768	2229	2706	3212	3758	4353	5006
	3 I absorbée	(A)	4.36	4.84	5.36	5.94	6.58	7.30	8.11
	4 Tc	(°C)	38.9	40.3	41.9	43.9	46.1	48.5	51.1
43	1 P frigorifique	(Watt)	782	1647	2605	3650	4772	5965	7228
	2 P absorbée	(W)	1358	1915	2475	3055	3666	4319	5023
	3 I absorbée	(A)	3.92	4.50	5.11	5.76	6.47	7.26	8.14
	4 Tc	(°C)	49.4	50.5	51.9	53.6	55.6	57.7	59.9

1 = cooling capacity 2 = power input 3 = current 4 = condensing temperature 5 = ambient temperature 6 = evaporating temperature

Nota : Tecumseh se réserve le droit de modifier les informations contenues dans ce document sans préavis.

Note : Tecumseh reserves the right to change information contained in this document without notification.

© 2021 Tecumseh Products Company
All rights reserved



Tecumseh

TAGT2516ZBR-TZ	Tension TZ : 400V 3~ 50Hz / 440V 3~ 60 Hz
-----------------------	--

Les performances sont données dans les conditions Standard TE :	Gaz aspirés :	32.0 °C
Condition Dew	Sous refroidissement :	2.0 K
The performance data are in Standard TE conditions :	Return gas :	32.0 °C
Dew Condition	Subcooling :	2.0 K

50 Hz R448A (*)							
							N°7058
5 T ambience	6 T évaporation	(°C)	-30	-25	-20	-15	-10
25	1 P frigorifique	(Watt)	2862	3933	5178	6587	8142
	2 P absorbée	(W)	2098	2475	2883	3330	3822
	3 I absorbée	(A)	4.76	5.25	5.81	6.41	7.05
	4 Tc	(°C)	30.6	32.5	34.6	37.0	39.8
32	1 P frigorifique	(Watt)	2429	3402	4541	5840	7284
	2 P absorbée	(W)	2083	2479	2905	3367	3872
	3 I absorbée	(A)	4.75	5.27	5.85	6.47	7.13
	4 Tc	(°C)	36.8	38.5	40.5	42.8	45.4
43	1 P frigorifique	(Watt)	1785	2612	3590	4720	5995
	2 P absorbée	(W)	2014	2443	2901	3392	3924
	3 I absorbée	(A)	4.69	5.24	5.85	6.50	7.19
	4 Tc	(°C)	46.6	48.1	49.9	51.9	54.2

60 Hz R448A (*)							
							N°7058
5 T ambience	6 T évaporation	(°C)	-30	-25	-20	-15	-10
25	1 P frigorifique	(Watt)	3173	4386	5772	7321	9014
	2 P absorbée	(W)	2443	2897	3387	3922	4512
	3 I absorbée	(A)	4.94	5.46	6.04	6.70	7.44
	4 Tc	(°C)	35.3	37.1	39.1	41.4	44.1
32	1 P frigorifique	(Watt)	2626	3753	5050	6506	8110
	2 P absorbée	(W)	2355	2849	3375	3941	4557
	3 I absorbée	(A)	4.85	5.41	6.03	6.72	7.49
	4 Tc	(°C)	41.9	43.5	45.4	47.5	50.0
43	1 P frigorifique	(Watt)		2799	3955	5271	
	2 P absorbée	(W)		2666	3263	3891	
	3 I absorbée	(A)		5.21	5.90	6.67	
	4 Tc	(°C)		53.6	55.3	57.1	

1 = cooling capacity 2 = power input 3 = current 4 = condensing temperature 5 = ambient temperature 6 = evaporating temperature

(*) Veuillez vous référer strictement aux Recommandations d'Utilisation et Bulletins Marketing Tecumseh du fait de la température de reflux élevée pour les applications LBP.
 (*) Due to very high discharge temperature especially on LBP conditions, please strictly refer to Tecumseh Guidelines & Marketing Bulletin when using this refrigerant.

Nota : Tecumseh se réserve le droit de modifier les informations contenues dans ce document sans préavis.
Note : Tecumseh reserves the right to change information contained in this document without notification.

© 2021 Tecumseh Products Company
All rights reserved



Tecumseh

TAGT2516ZBR-TZ	Tension TZ : 400V 3~ 50Hz / 440V 3~ 60 Hz
-----------------------	--

Les performances sont données dans les conditions Standard TE :	Gaz aspirés :	32.0 °C
Condition Dew	Sous refroidissement :	2.0 K
The performance data are in Standard TE conditions :	Return gas :	32.0 °C
Dew Condition	Subcooling :	2.0 K

50 Hz R449A (*)							
							N°6832
5 T ambience	6 T évaporation	(°C)	-30	-25	-20	-15	-10
25	1 P frigorifique	(Watt)	2865	3937	5184	6595	8153
	2 P absorbée	(W)	2098	2475	2883	3330	3822
	3 I absorbée	(A)	4.76	5.25	5.81	6.41	7.05
	4 Tc	(°C)	30.6	32.5	34.6	37.0	39.8
32	1 P frigorifique	(Watt)	2432	3407	4547	5848	7294
	2 P absorbée	(W)	2083	2479	2905	3367	3872
	3 I absorbée	(A)	4.75	5.27	5.85	6.47	7.13
	4 Tc	(°C)	36.8	38.5	40.5	42.8	45.4
43	1 P frigorifique	(Watt)	1788	2615	3595	4727	6004
	2 P absorbée	(W)	2014	2443	2901	3392	3924
	3 I absorbée	(A)	4.69	5.24	5.85	6.50	7.19
	4 Tc	(°C)	46.5	48.1	49.9	51.9	54.1

60 Hz R449A (*)							
							N°6832
5 T ambience	6 T évaporation	(°C)	-30	-25	-20	-15	-10
25	1 P frigorifique	(Watt)	3176	4391	5780	7330	9026
	2 P absorbée	(W)	2443	2897	3387	3922	4512
	3 I absorbée	(A)	4.94	5.46	6.04	6.70	7.44
	4 Tc	(°C)	35.3	37.1	39.1	41.4	44.1
32	1 P frigorifique	(Watt)	2629	3759	5057	6515	8122
	2 P absorbée	(W)	2355	2849	3375	3941	4557
	3 I absorbée	(A)	4.85	5.41	6.03	6.72	7.49
	4 Tc	(°C)	41.9	43.5	45.4	47.5	49.9
43	1 P frigorifique	(Watt)		2803	3961	5279	
	2 P absorbée	(W)		2666	3263	3891	
	3 I absorbée	(A)		5.21	5.90	6.67	
	4 Tc	(°C)		53.6	55.2	57.1	

1 = cooling capacity 2 = power input 3 = current 4 = condensing temperature 5 = ambient temperature 6 = evaporating temperature

(*) Veuillez vous référer strictement aux Recommandations d'Utilisation et Bulletins Marketing Tecumseh du fait de la température de refoulement élevée pour les applications LBP.
 (*) Due to very high discharge temperature especially on LBP conditions, please strictly refer to Tecumseh Guidelines & Marketing Bulletin when using this refrigerant.

Nota : Tecumseh se réserve le droit de modifier les informations contenues dans ce document sans préavis.
Note : Tecumseh reserves the right to change information contained in this document without notification.

© 2021 Tecumseh Products Company
All rights reserved