

Condensing unit
Voltage Code : FZ

CAJN9480ZMHR-FZ

High Temp. Commercial (MHP)

220 - 240V 1~ 50 Hz

R452A / R404A / R448A / R449A

CAJN9480ZMHR-FZ

Conditions	Frequency	Nominal Cooling Capacity		Sound Power ISO3745 / ISO 3743-1
		Watts	BTU/h	
EN13215 / R452A	50 Hz	1157	3944	64 dBA
EN13215 / R404A	50 Hz	1212	4134	64 dBA
EN13215 / R448A	50 Hz	1060	3616	64 dBA
EN13215 / R449A	50 Hz	1061	3618	64 dBA

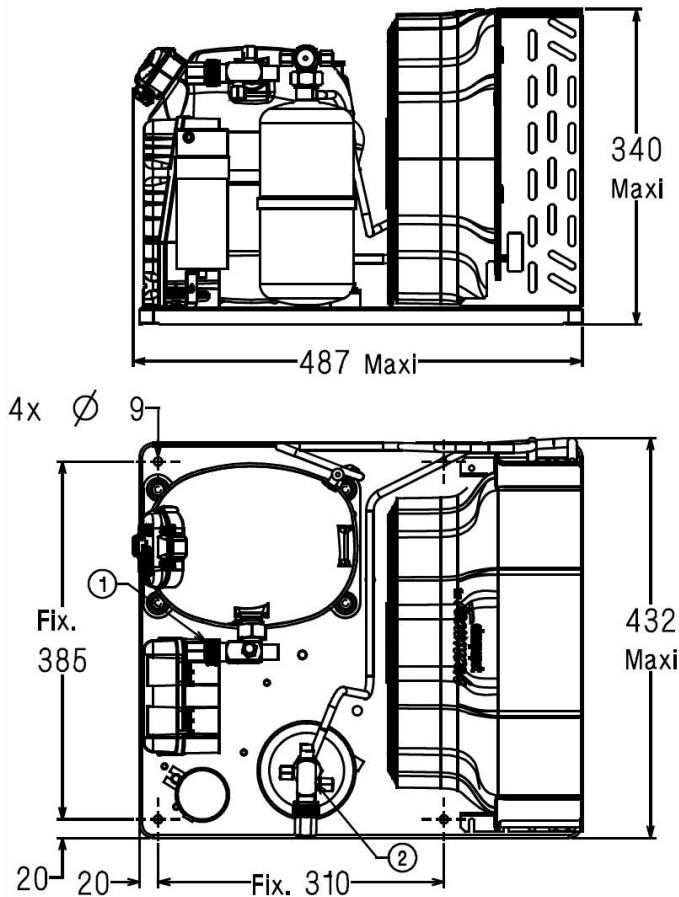

* EN13215 : T°Ambient 32.0°C / T°Evap. -10.0°C / T°Return gas temp.. 20.0°C
T°Subcooling. 3.0K

Net Weight (Kg)	33.0
Expansion device	Expansion_Valve
Air Flow (m³/h)	900
Compo Data Sheet	224CT-FZ
Elec Comp Type	CSR
Current (Amp)	
Load Rated Amp	4.5
Max Cont Current	6.9
Lock Rotor Amp	23
Fan	
Speed (rpm)	1200
Power (W)	30.0
Diameter (mm)	300
Protection	Overload
IP Level	IP54
Condenser	300/3900
Liquid Receiver	
Capacity (L)	1.5
Maximum Pressure (Bars)	32.0
Suction Line	
Suction Type	Vanne Orientable
For Tubing Out Diam	12.7 (1/2")
Suction Connection Type	Brased
Liquid Line	
Liquid Line Type	Vanne Orientable
For Tubing Out Diam	9.5 (3/8")
Liquid Connecton Type	Brased
Connection Type	VR
Fan Guard	maille < à 8mm

Note : Tecumseh reserves the right to change information contained in this document without notification.



Tecumseh

CAJN9480ZMHR-FZ	Tension FZ : 220 - 240V 1~ 50 Hz
------------------------	---

Les performances sont données dans les conditions EN13215 :	Gaz aspirés :	20.0 °C
Condition Dew	Sous refroidissement :	3.0 K
The performance data are in EN13215 conditions :	Return gas :	20.0 °C
Dew Condition	Subcooling :	3.0 K

© 2021 Tecumseh Products Company
All rights reserved

50 Hz R452A

N°6288

5 T ambience	6 T évaporation	(°C)	-25	-20	-15	-10	-5	0	5	10	15
25	1 P frigorifique	(Watt)	678	861	1069	1299	1552	1823	2110	2409	2716
	2 P absorbée	(W)	493	550	608	668	731	797	867	942	1022
	3 I absorbée	(A)	2.47	2.72	2.98	3.25	3.53	3.83	4.15	4.49	4.86
	4 Tc	(°C)	30.3	32.1	34.0	36.1	38.3	40.7	43.2	45.9	48.8
32	1 P frigorifique	(Watt)	583	756	947	1157	1383	1625	1880	2144	2415
	2 P absorbée	(W)	495	559	624	691	761	835	912	994	1082
	3 I absorbée	(A)	2.43	2.73	3.03	3.34	3.66	4.00	4.35	4.73	5.13
	4 Tc	(°C)	36.5	38.2	40.0	41.9	44.0	46.2	48.6	51.2	53.9
43	1 P frigorifique	(Watt)		586	753	930	1118	1316	1521	1734	
	2 P absorbée	(W)		563	640	720	802	888	978	1073	
	3 I absorbée	(A)		2.71	3.08	3.46	3.85	4.24	4.65	5.08	
	4 Tc	(°C)		47.8	49.4	51.1	53.0	55.0	57.2	59.5	

50 Hz R404A

N°5047

5 T ambience	6 T évaporation	(°C)	-25	-20	-15	-10	-5	0	5	10	15
25	1 P frigorifique	(Watt)	737	923	1132	1362	1612	1878	2155	2439	2726
	2 P absorbée	(W)	521	578	637	697	759	823	890	961	1038
	3 I absorbée	(A)	2.61	2.86	3.12	3.38	3.66	3.95	4.26	4.58	4.94
	4 Tc	(°C)	33.2	34.9	36.8	38.8	41.0	43.3	45.7	48.3	51.0
32	1 P frigorifique	(Watt)	637	811	1004	1212	1435	1670	1914	2162	2410
	2 P absorbée	(W)	526	590	655	722	791	863	937	1016	1099
	3 I absorbée	(A)	2.58	2.88	3.18	3.49	3.80	4.13	4.47	4.83	5.21
	4 Tc	(°C)	39.3	40.9	42.6	44.5	46.5	48.6	50.9	53.3	55.9
43	1 P frigorifique	(Watt)		634	801	976	1158	1347	1538	1732	
	2 P absorbée	(W)		599	676	755	836	920	1006	1097	
	3 I absorbée	(A)		2.88	3.26	3.63	4.00	4.39	4.78	5.19	
	4 Tc	(°C)		50.2	51.6	53.3	55.0	57.0	59.0	61.2	

1 = cooling capacity 2 = power input 3 = current 4 = condensing temperature 5 = ambient temperature 6 = evaporating temperature

Nota : Tecumseh se réserve le droit de modifier les informations contenues dans ce document sans préavis.

Note : Tecumseh reserves the right to change information contained in this document without notification.



Tecumseh

CAJN9480ZMHR-FZ	Tension FZ : 220 - 240V 1~ 50 Hz
------------------------	---

Les performances sont données dans les conditions EN13215 :	Gaz aspirés :	20.0 °C
Condition Dew	Sous refroidissement :	3.0 K
The performance data are in EN13215 conditions :	Return gas :	20.0 °C
Dew Condition	Subcooling :	3.0 K

© 2021 Tecumseh Products Company
All rights reserved

50 Hz R448A (*)

N°6979

5 T ambience	6 T évaporation	(°C)	-25	-20	-15	-10	-5	0	5	10	15
25	1 P frigorifique	(Watt)	576	754	957	1186	1440	1719	2021	2346	2690
	2 P absorbée	(W)	465	519	576	635	699	765	837	913	996
	3 I absorbée	(A)	2.32	2.57	2.82	3.09	3.37	3.68	4.00	4.36	4.74
	4 Tc	(°C)	30.7	32.5	34.4	36.5	38.8	41.2	43.7	46.4	49.2
32	1 P frigorifique	(Watt)		661	850	1060	1293	1547	1822	2117	2430
	2 P absorbée	(W)		529	592	659	729	804	884	969	1060
	3 I absorbée	(A)		2.58	2.88	3.19	3.51	3.86	4.22	4.61	5.02
	4 Tc	(°C)		38.6	40.4	42.4	44.4	46.7	49.1	51.6	54.3
43	1 P frigorifique	(Watt)				866	1066	1282			
	2 P absorbée	(W)				688	772	860			
	3 I absorbée	(A)				3.31	3.70	4.11			
	4 Tc	(°C)				51.6	53.5	55.5			

50 Hz R449A (*)

N°6221

5 T ambience	6 T évaporation	(°C)	-25	-20	-15	-10	-5	0	5	10	15
25	1 P frigorifique	(Watt)	576	754	957	1186	1440	1719	2022	2347	2691
	2 P absorbée	(W)	465	519	576	635	699	765	837	913	996
	3 I absorbée	(A)	2.32	2.57	2.82	3.09	3.37	3.68	4.00	4.36	4.74
	4 Tc	(°C)	30.7	32.5	34.4	36.5	38.8	41.1	43.7	46.4	49.2
32	1 P frigorifique	(Watt)		661	850	1061	1293	1548	1823	2118	2431
	2 P absorbée	(W)		529	592	659	729	804	884	969	1060
	3 I absorbée	(A)		2.58	2.88	3.19	3.51	3.86	4.22	4.61	5.02
	4 Tc	(°C)		38.6	40.4	42.3	44.4	46.7	49.1	51.6	54.3
43	1 P frigorifique	(Watt)				866	1066	1283			
	2 P absorbée	(W)				688	772	860			
	3 I absorbée	(A)				3.31	3.70	4.11			
	4 Tc	(°C)				51.6	53.4	55.4			

1 = cooling capacity 2 = power input 3 = current 4 = condensing temperature 5 = ambient temperature 6 = evaporating temperature

(*) Veuillez vous référer strictement aux Recommandations d'Utilisation et Bulletins Marketing Tecumseh du fait de la température de reflux élevée pour les applications LBP.

(*) Due to very high discharge temperature especially on LBP conditions, please strictly refer to Tecumseh Guidelines & Marketing Bulletin when using this refrigerant.

Nota : Tecumseh se réserve le droit de modifier les informations contenues dans ce document sans préavis.

Note : Tecumseh reserves the right to change information contained in this document without notification.